

Mechanical Cam Switches
BNS 819-B03-R08-40-13-S80R
 Order Code: BNS01U5

BALLUFF

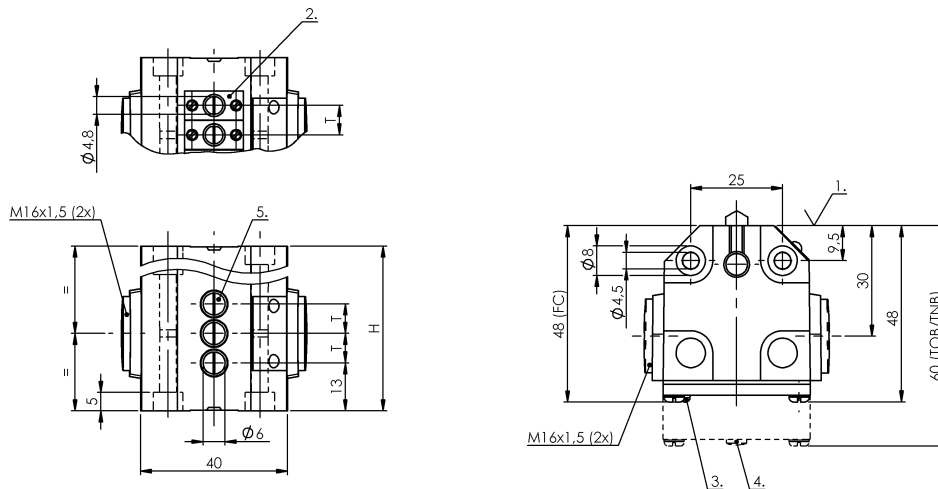

1) Reference edge, 2) Anti-crystallization plunger, 3) Function indicator FC, 4) Function indicator FD/FE/LL, 5) 1st pos.



Basic features

Approval/Conformity	CE WEEE
Basic standard	IEC 60947-5-1
Operating principle	1-3. Switch position: Mechanical
Version	Snap contact

Display/Operation

Function indicator	1-3. Switch position: None
--------------------	----------------------------

Electrical connection

Connection	M12x1-Flange male, 5-pin
Connection type	1. Switch position: Connector

Electrical data

Connector, order code	BKS-S 80-G-PU-05 (straight) BKS-S 80-W-PU-05 (right-angle)
Continuous current	1-3. Switch position: 0.1 A
Rated operating voltage U _e	1-3. Switch position: 250 V AC
Switching rate	1-3. Switch position: 200/min

Environmental conditions

Ambient temperature	-5...85 °C
IP rating	IP67

Functional safety

B10d (EN ISO 13849-1)	BSE 74.1: 10 mil. switching cycles
-----------------------	------------------------------------

Material

Housing material	Aluminium, Anodized
Housing material, surface protection	Anodized
Material contacts	1-3. Switch position: Gold
Plunger material	1-3. Switch position: 1.4034 stainless steel

Mechanical data

Approach direction	longitudinal, parallel to attachment surface
Approach speed	1-3. Switch position: 60 m/min
Dimension	40 x 42 x 48 mm
Distance cam - reference edge	1-3. Switch position: 2.30...2.80 mm
Flange, feed-through	None
Installation	Vertical
Life expectancy mechanical	1-3. Switch position: 10 mil. switching operations
Number of switching positions	3x Roller Mechanical
Plunger spacing 1st switch position	13 mm
Plunger style	1-3rd switch position: Roller 1-3rd switch position: Roller
Switch actuation force	1-3. Switch position: 8 N
Switching element	1-3. Switch position: BSE 74.1

Range/Distance

Reproducibility	1-3. Switch position: ±0.05 mm
Switch position spacing	8 mm

Connector Drawings

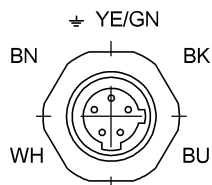

View of connector side

Wiring Diagrams

